



:



دهمین کنفرانس ملی مهندسی شیمی ایران

دانشگاه سیستان و بلوچستان
۲۶ - ۲۴ آبان ماه ۱۳۸۴

*

pezeshk@sharif.edu :

taghikhani@sharif.edu :

esaadatpoor@yahoo.com :

shahvali2000@yahoo.com :





:

¹ Regression Analysis

² Artificial Neural Networks (ANN)



:

()

()

)

(

¹ Permeability

² Porosity

³ Regression Analysis

⁴ Artificial Neural Networks (ANN)

p

(Bias)

()

a

b, ω

f

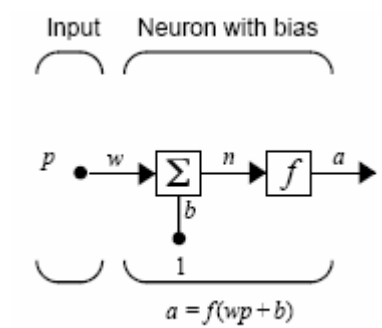

()

¹ Neuron
^v Activation Function

(f)

$f(x) = x$
 $f(x) = \begin{cases} 1 & x \geq 0 \\ 0 & x < 0 \end{cases}$
 $f(x) = \frac{1}{1 + \exp(-x)}$

() ()

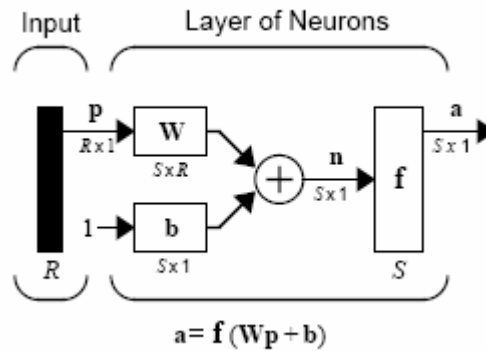
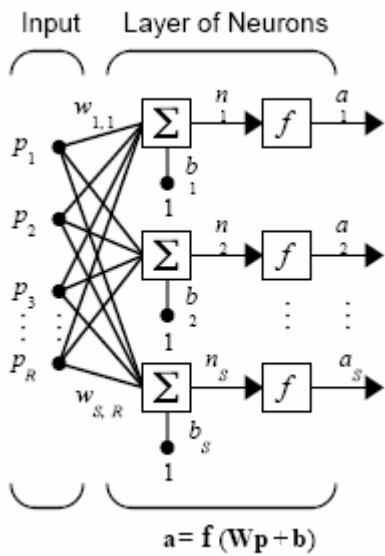

Where...

R = number of elements in input vector

S = number of neurons in layer 1

()

()

()



:

$$B^k W^k$$

$$b_i \quad w_{ij}$$

⋮
⋮

(

m

n

⋮

(

Feed Forward
Supervised Training
Training Algorithm

N 4BP

(X(k), D(k))

Y(k)

: K E(k)

$E(k) = D(k) - Y(k)$ ()

k

:

$$\hat{F}(k) = \sum_{i=1}^{n(L)} e_i^2(k) = E(k) \times E(k)^T \quad ()$$

$\hat{F}(k)$

¹ Unsupervised Training
² Self Organizing Neural Network
³ Target Values
⁴ Back Propagation



:

$$\hat{F}_{av}(c) = \frac{1}{N} \sum_{i=1}^N \hat{F}(cN - i) \quad (1)$$

$$\hat{F}(k) = \hat{F}(k) \quad (2)$$

$$\frac{\partial \hat{F}(k)}{\partial b_i^l(k)} \quad \frac{\partial \hat{F}(k)}{\partial w_{ij}^l(k)}$$

$$\begin{cases} w_{ij}^l(k+1) = w_{ij}^l(k) - \alpha \frac{\partial \hat{F}(k)}{\partial w_{ij}^l(k)} \\ b_i^l(k+1) = b_i^l(k) - \alpha \frac{\partial \hat{F}(k)}{\partial b_i^l(k)} \end{cases} \quad (3)$$

$$\frac{\partial F(k)}{\partial b_i^L(k)} \quad \frac{\partial F(k)}{\partial w_{ij}^L(k)}$$

BP

BP

$$\nabla_z = - \underbrace{[\nabla_z^2 J(z)]}^{-1}_{M \times M} \times \underbrace{\nabla_z J(z)}_{M \times 1} \quad (4)$$

: M

¹ Levenberg-Marquardt



:

:N

:n(L)

$$\underbrace{\nabla_z^2 J(z)}_{M \times M} = \underbrace{J^T(z)}_{M \times (N \cdot n(L))} \cdot \underbrace{J(z)}_{(N \cdot n(L)) \times M} + \underbrace{R(z)}_{M \times M} \quad ()$$

$$\underbrace{\nabla_z J(z)}_{M \times 1} = \underbrace{J^T(z)}_{M \times (N \cdot n(L))} \cdot \underbrace{E(z)}_{(N \cdot n(L)) \times 1} \quad ()$$

$$: \quad R(z) \cong 0$$

$$\nabla_z = -[J^T(z) \cdot J(z)]^{-1} \times [J^T(z) \cdot E(z)] \quad ()$$

:

$$\nabla_z = -[J^T(z) \cdot J(z) + \eta I]^{-1} \times [J^T(z) \cdot E(z)] \quad ()$$

 η

BP

 η

()

(+)

/ + /

$$(\sum w_i x_i)$$

$$(\sum w_i x_i)$$

« »

()

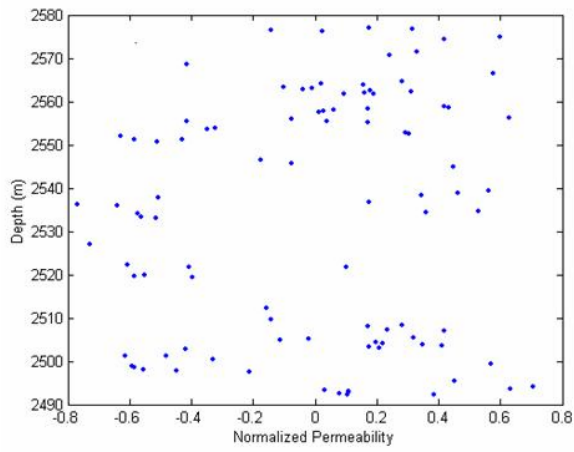

()

/ + /

(/)

Saturated Network



:

()

-
- \ Shuffling
 - v Training Data
 - v Validation Data
 - ε Test Data
 - ° Generalization



:

(())

()

)

(

MSE

()

MSE=10⁻⁴

tansig

tansig

purelin

MATLAB

:

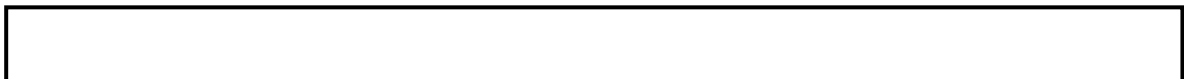

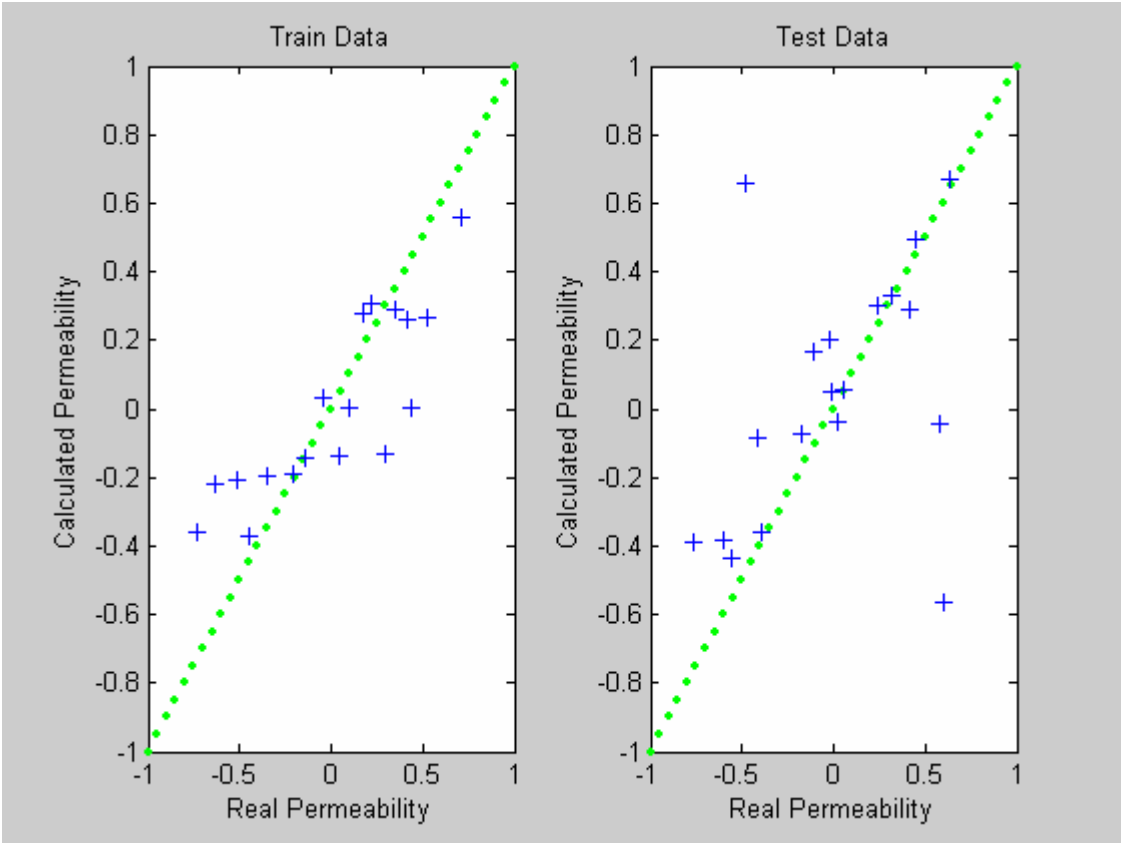

()

()

()

. % ,
% ,

()

. % ,

¹ Absolute Mean Average Error
² Mean Square Error
³ Epoch



:

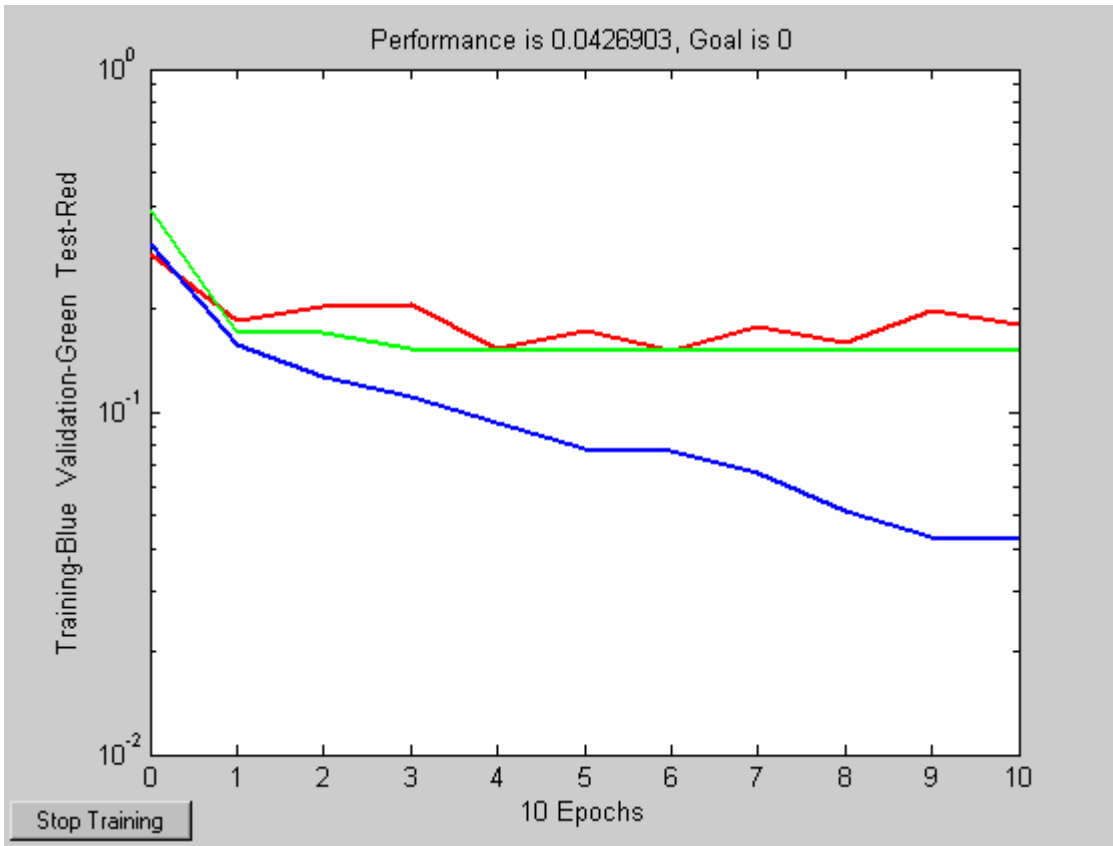

()



MSE